Pressure / Flow Test Bench

Description

The proposed system is an integrated assembly used to perform Flow & Pressure Testing on hydraulic filters.

Architecture

The pump and flow meters reside underneath the stainless steel reservoir holding the hydraulic test fluid. The tank has a vent and fill port as well as a level site gauge. Above the tank resides the area for the unit under test. This section is enclosed on all sides and the top with clear plexiglass that provides for 360 degree inspection of the test subject while protecting the operator.

The test subject is fixed to the rigid return line supported sufficiently to hold the test subject. The feed to the test subject is via a stainless steel braided hose.

A drip pan below the test subject has a perforated sheet to prevent tools and fasteners from falling into the reservoir.

A control panel is attached to the end of the bench and includes a desk top workspace for the keyboard and mouse. The monitor is vesa mounted to allow for viewing from various angles.

Flow Testing Process

Fluid is drawn from the reservoir and moved to the test subject with a positive displacement gear pump. The pump is controlled by a variable speed drive that the control will use to vary the flowrates during testing. The pump can generate 65 GPM at 50 PSI.

To accurately control and monitor the flows over the extended range 100:1, the system has two flow paths that effectively provides two paths each with a 20:1 range. The operator selects the high or low flow range by manipulating hand valves. The high flow range transfers the full flow to the test subject and allows for precise control and monitoring from 5 to 65 GPM. For flow ranges of 0-10GPM or lower, the path is split with a portion of the fluid diverted back to the tank. By installing flow control orifices to the feed and return paths, the flow can be controlled more precisely with the same speed control. The orifices are designed such that the overall flow is split proportionally between the feed and return, so with the pump transferring say 5 GPM, 1 GPM of the flow is moved to the test subject and 4 GPM returned to the orifice. With the pump moving 50 GPM, 10 GPM is sent to the test subject and 40 GPM returned to the tank.

The flowrate is measured using gear type meters that are provided with 10-point NIST calibration certificates. This flow is transferred to the test subject through isolation valves and a stainless steel braided hose with quick disconnects.

Pressure / Flow Test Bench

A precision differential pressure transmitter is provided with an NIST calibration certificate. The paths are also monitored for pressure and temperature. These parameters are used by the data acquisition system to provide volumetric flow data correlated to standard pressure and temperature per API guidelines.

Flow Testing Operational Procedure

The operator first manipulates the valves for the High or Low Range. With a test subject in place, the operator will jog the pump to clear any air from the system. He will then enter the desired flow range, the data collection rate, and the number of cycles for the testing and then presses go. These settings are stored in a database and can be retrieved by name in the future.

The system will ramp the flowrate up at a preprogrammed rate and record the flowrate, temperature, pressure, and differential pressure continuously. The temperature and pressure are used by the program to correct the flow to standard pressure and temperature. The corrected flowrate and differential pressure are logged by the system as the flowrate is ramp up to the high range and then down to the low range. This is repeated for the desired number of cycles and the system stops automatically.

The data is presented in a graph that the operator reviews before pushing the create report button that generates a pdf file.

Optional Burst / Leak Testing Process

The burst testing uses the same reservoir but a separate path to accommodate high pressure. The fluid is transferred using an air operated diaphragm. The pump pressure output is controlled using a precision I/P and requires 150 PSI air to achieve 50,000 PSI. The pump transfers the fluid to the test subject through a motorized valve that is used to isolate the test subject during leak testing. After this valve there is a pressure gauge and a pressure transmitter for measurement. Downstream of the test subject is a manual needle valve. This needle valve is opened prior to testing to remove any air in the system.

Burst / Leak Testing Operational Procedure

The controller can perform a routine that includes all the tests below. That is each type of test can be run alone or in conjunction with others. Each routine is stored in the database and can be retrieved by name.

1. Ramp and Hold: The pressure on the UUT is increased at a set rate and then held at the setpoint for a set time. It can then ramp and hold at a higher setpoint or perform another type of test.
2. Ramp to Burst: The pressure on the UUT is increased at a set rate until failure. Once a burst is detected by a drop in pressure, the test is ended with the residual pressure removed and the part isolated.
3. Leak Test: This test is used in conjunction with a ramp hold. The pressure is increased to a setpoint and the part is isolated with the automatic valve. The pressure is monitored during the set time period and the deviation recorded. If the deviation is outside of the limits, the test is aborted.

The operator installs the test subject and jogs the pump while watching the flow coming out of the test subject and into the drip pan. Once satisfied that the air has been removed, the outlet valve is closed by hand.

The operator then selects a test routine or creates a new one based on any combination of the Ramp, Burst, and Leak testing. He presses the start button and the test proceeds until the routine is complete.

PC & Software

The proposal will run a Labview executable to perform the tests and record data. A Nation Instruments USB DAQ has 16-bit resolution for recording.

The DAQ and variable speed drive are housed within an electrical cabinet. The system includes a master start and emergency stop.

An HP small form factor PC is included with a 19" Monitor attached to a Vesa arm.

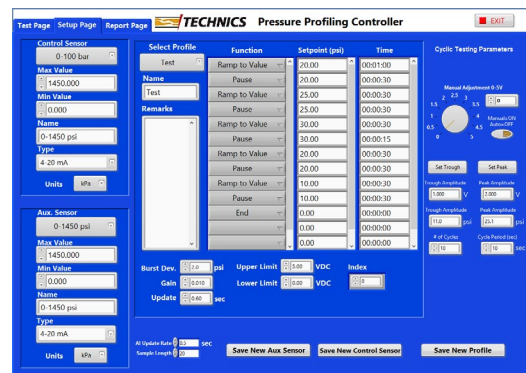
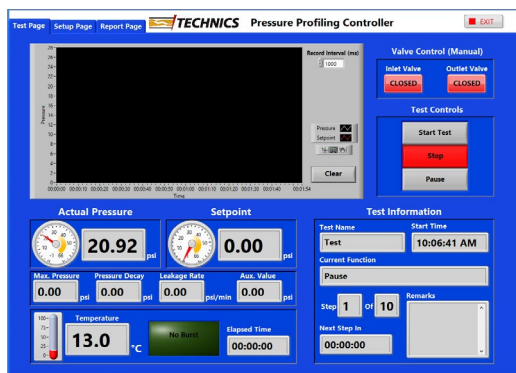

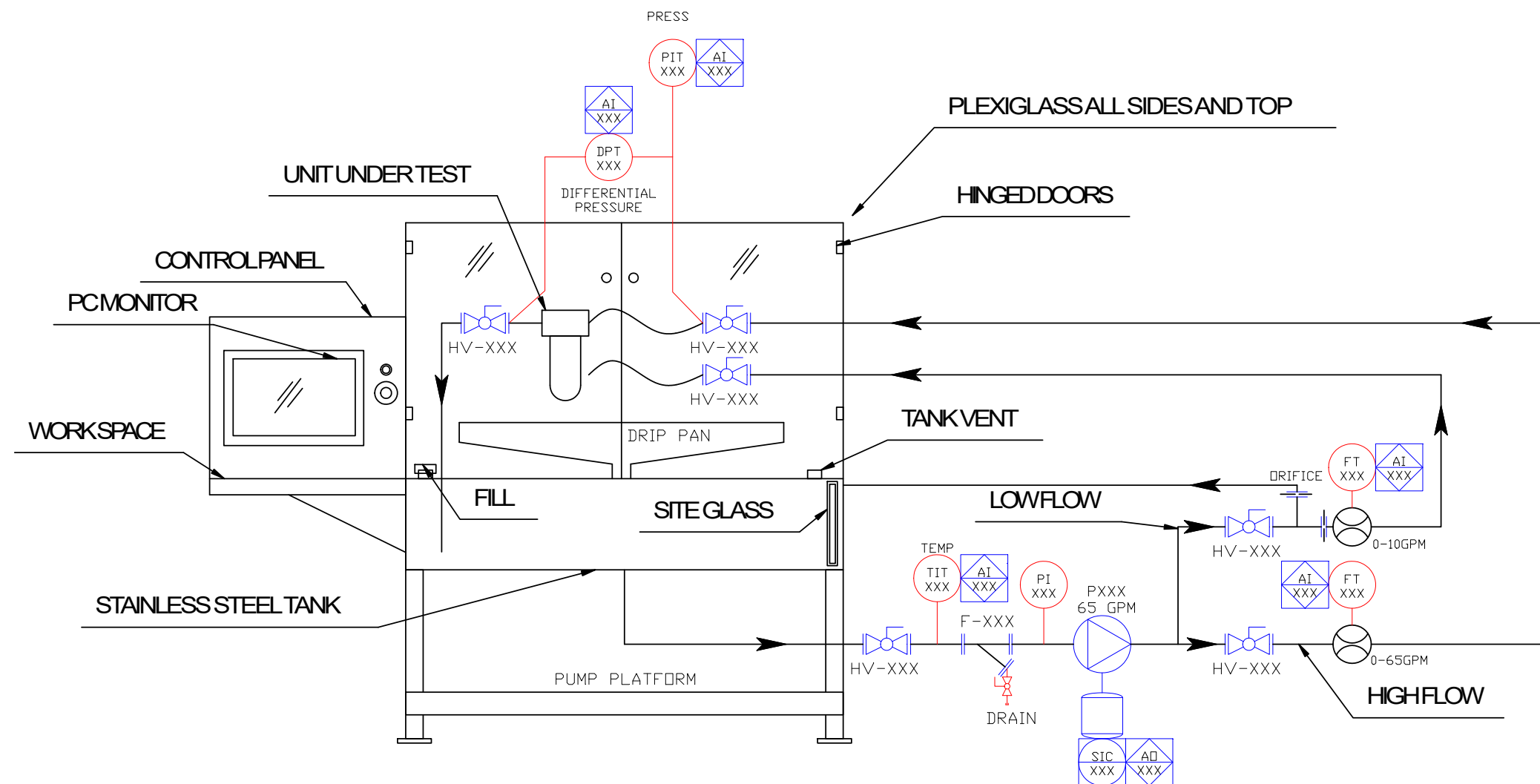

DIFFERENTIAL PRESSURE / FLOW TESTING DIAGRAM

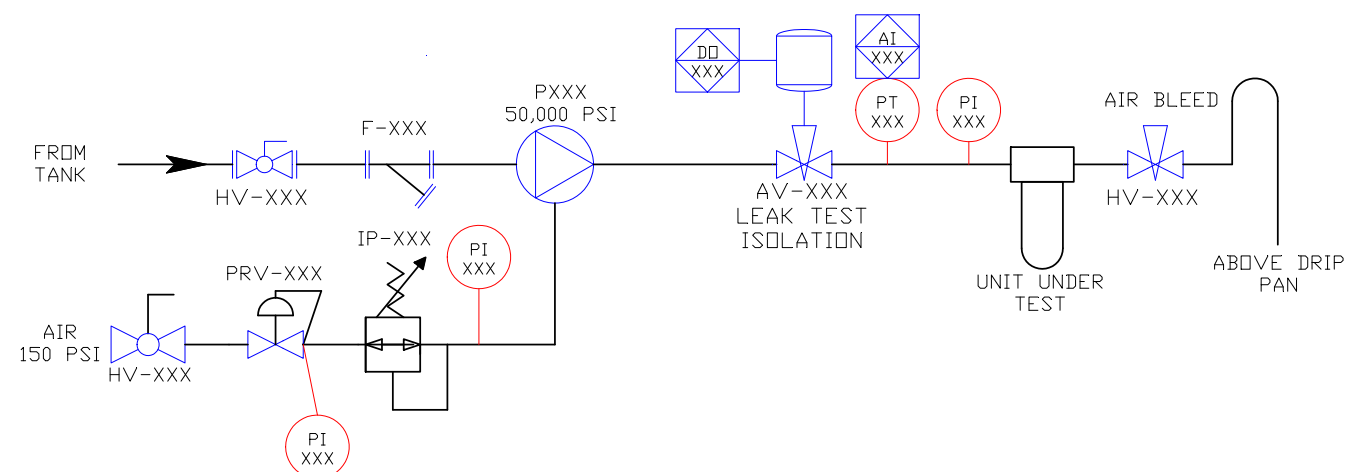

LEAK & BURST TESTING DIAGRAM

LTR	DATE	BY	DESCRIPTION

REVISIONS			

CONFIDENTIAL
THIS DRAWING SHALL BE USED ONLY AS SPECIFIED BY TECHNICS. ANY OTHER USE, REPRODUCTION OR DISCLOSURE TO OTHERS WITHOUT WRITTEN PERMISSION IS PROHIBITED.

ENGINEER APPROVAL BY:		DATE	
DRAWN BY:		DATE	
SCALE		NTS	

CLIENT	
PROJECT TITLE	
LOCATION	

SHEET TITLE	PROCESS & INSTRUMENTATION DIAGRAM	
SIZE	SHEET	NUMBER
B	1 OF 1	